



# Packaging Dynamics, Ltd.

35B Carlough Road, Bohemia, New York 11716

Tel: 631.563.4499 • Fax: 631.563.4893

## PORTABLE LIQUID FILLER MODEL: SL-4P



**ISSA**®  
The Experts  
on Cleaning and Maintenance

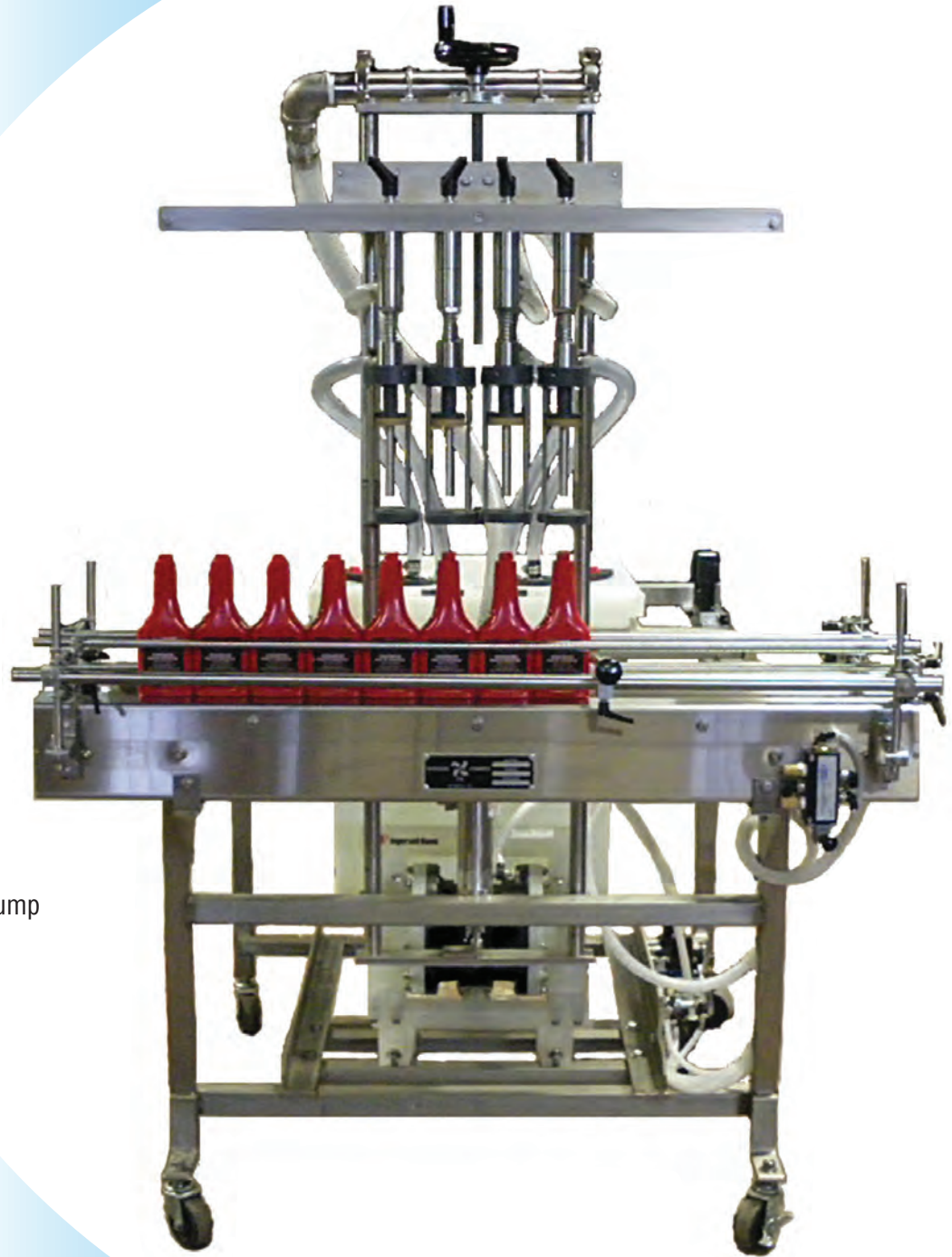

### Features

- Portable Design
- Fill to Level System
- Stainless Steel Contact Parts
- No-Electric Controls
- Portable Design
- Quick Change Rail Adjustments
- Quick Change Nozzle Adjustments
- 1.0" NPT Pneumatic Aro Diaphragm Pump
- NEMA 4 and Explosion-Proof
- (26) Gallon Polyurethane Tank
- Expandable to (8) HDS

### Options

- Stainless Steel Product Tank
- Stainless Steel Product Pump
- Gravity Feed Capabilities
- Bottom Feed Nozzles
- Product Mixer
- Sanitary Connections
- Semi-Automatic Indexing Systems
- 6' Pneumatically Driven Conveyor



# Packaging Dynamics, Ltd.

35B Carlough Road, Bohemia, New York 11716  
Tel: 631.563.4499 • Fax: 631.563.4893

## ENGINEERED FOR PORTABILITY AND CONVENIENCE

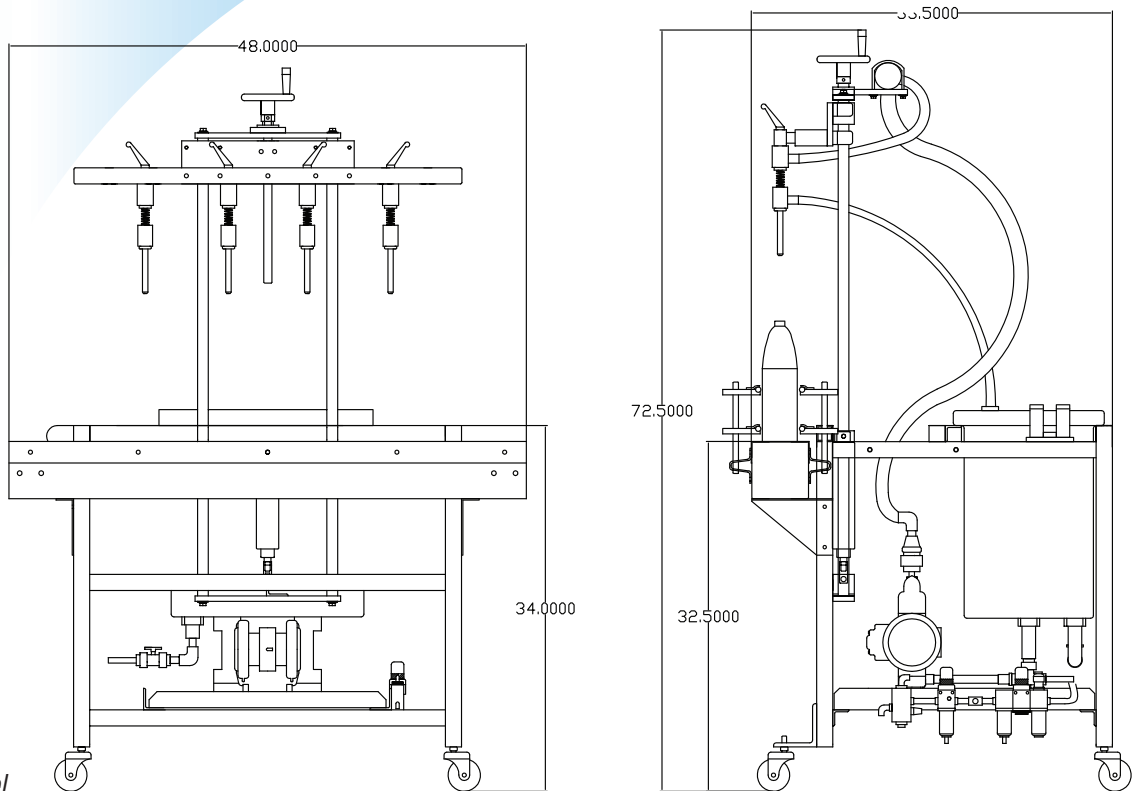

### BENCH MODEL B-4

The Packaging Dynamics, Ltd. Bench Model **B-4** Liquid Filler is an economical table top *fill-to-level* system designed for small production runs. It has been engineered for ease of operation with quick change-over features. Its non-electric pneumatic design can be used safely in hazardous locations.

### CART MODEL SL-4P

The Packaging Dynamics, Ltd. Cart Model **SL-4P** Liquid Filler is identical in operational features to the Model **B-4** with the exception that it is supplied with a roll-around cart which provides a greater range of portability. The **SL-4P** can be used for low production runs, cleaned and quickly stored or transported effortlessly to another plant location for use.

The **B-4** & **SL-4P** Liquid Fillers are currently being used in the pharmaceutical, beverage, chemical and cosmetic industries.

### Specifications

#### DESCRIPTION

Container size	2 oz to 2 1/2 gallons
Nozzles available	2 to 8
Construction	Stainless Steel/Aluminum
Overall dimensions	38.5"H x 28"W x 14" (B-4 Bench Model) 72.5"H x 38.5"W x 27.5"D (SL-4P Cart Model)
Air consumption	6 to 8 scfm
Weight	Approximately 75 lbs (B-4 Bench Model) Approximately 140 lbs (SL-4P Cart Model)
Controls	Manual container stop Pneumatic pump timer Pneumatic dwell timer Manual directional valve with automatic return
Production Rate	Subject to product and container review