



Packaging Dynamics, Ltd.

35B Carlough Road, Bohemia, New York 11716

Tel: 631.563.4499 • Fax: 631.563.4893

FULLY AUTOMATIC MASS FLOW LIQUID FILLER



Positive Closure Nozzles

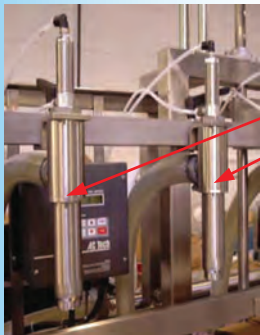

Re-circulating SS Valves to Prevent Over Pressurizing

Stainless Steel 316 Centrifugal Pump

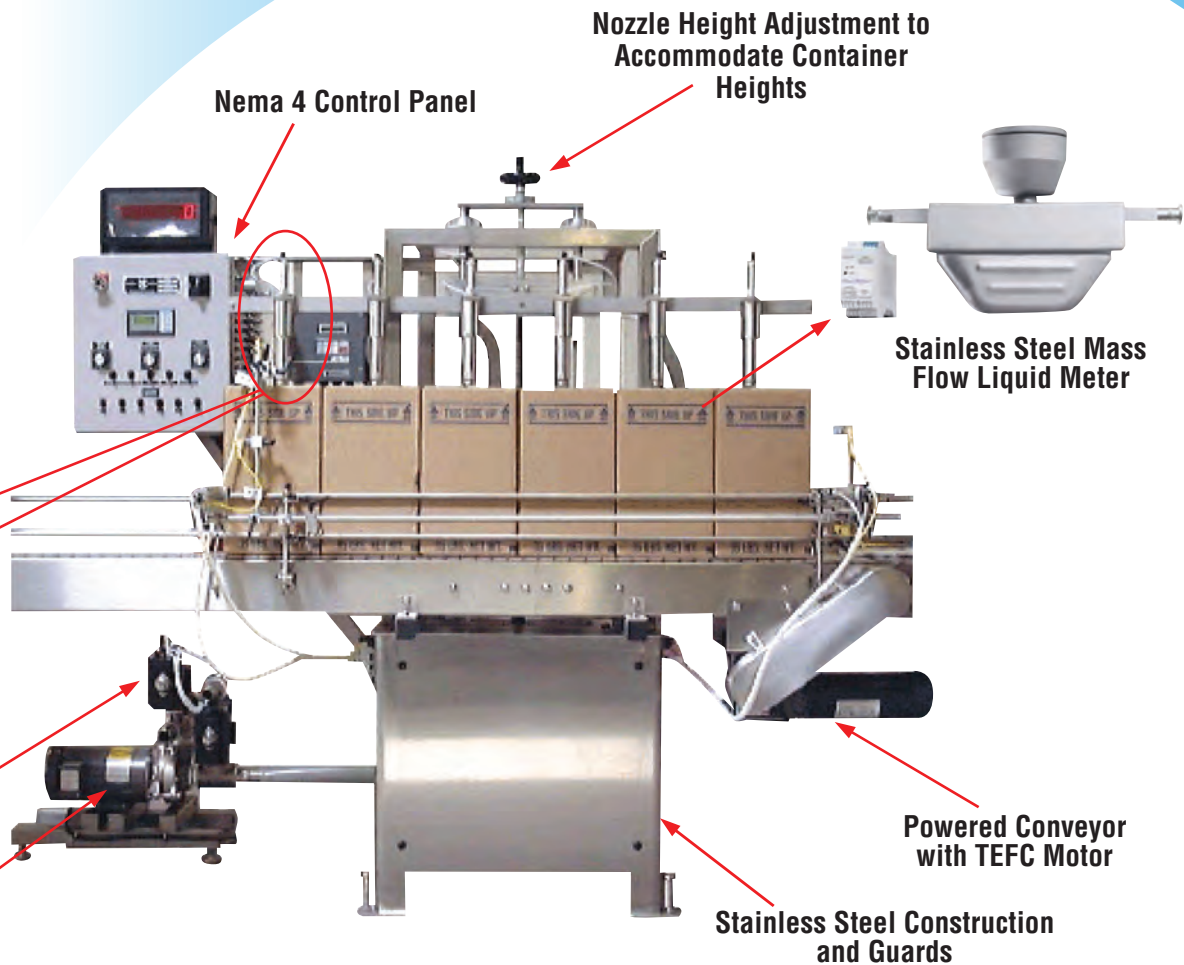

Features

- Fully-Automatic AB Control Package
- Micro Motion Coriolis Flow Meters
- Stainless Steel Frame & Conveyor
- Stainless Steel Contact Parts
- Stainless Steel Centrifugal Pump
- 0.5% Accuracy or Better
- Almost Any Nema Application
- 110 or 220 VAC Operation
- Quick Change Rail & Nozzle Adjustment
- Small to Drum Size Fills
- Mechanical Drip Tray

Benefits

- No Periodic Recalibration
- Flow Meters are Non Intrusive
- No Required Scheduled Maintenance
- Direct Mass Measurement
- Immune to Variations in Pressure or Temperature
- Ideal for Clean in Place Applications
- High Efficiency Drive Motors
- Quick Disconnect Fittings
- Easy Change Overs

Options

- Stainless Steel Tanks
- Splash Guard
- Bottom Fill Nozzles
- Centering Devices
- Sanitary Connections
- Explosion Proof Construction
- 220v AC Operation
- Stainless Steel Transfer Plate
- Incase Filling



Packaging Dynamics, Ltd.

35B Carlough Road, Bohemia, New York 11716
Tel: 631.563.4499 • Fax: 631.563.4893

ENGINEERED FOR ACCURACY & DEPENDABILITY

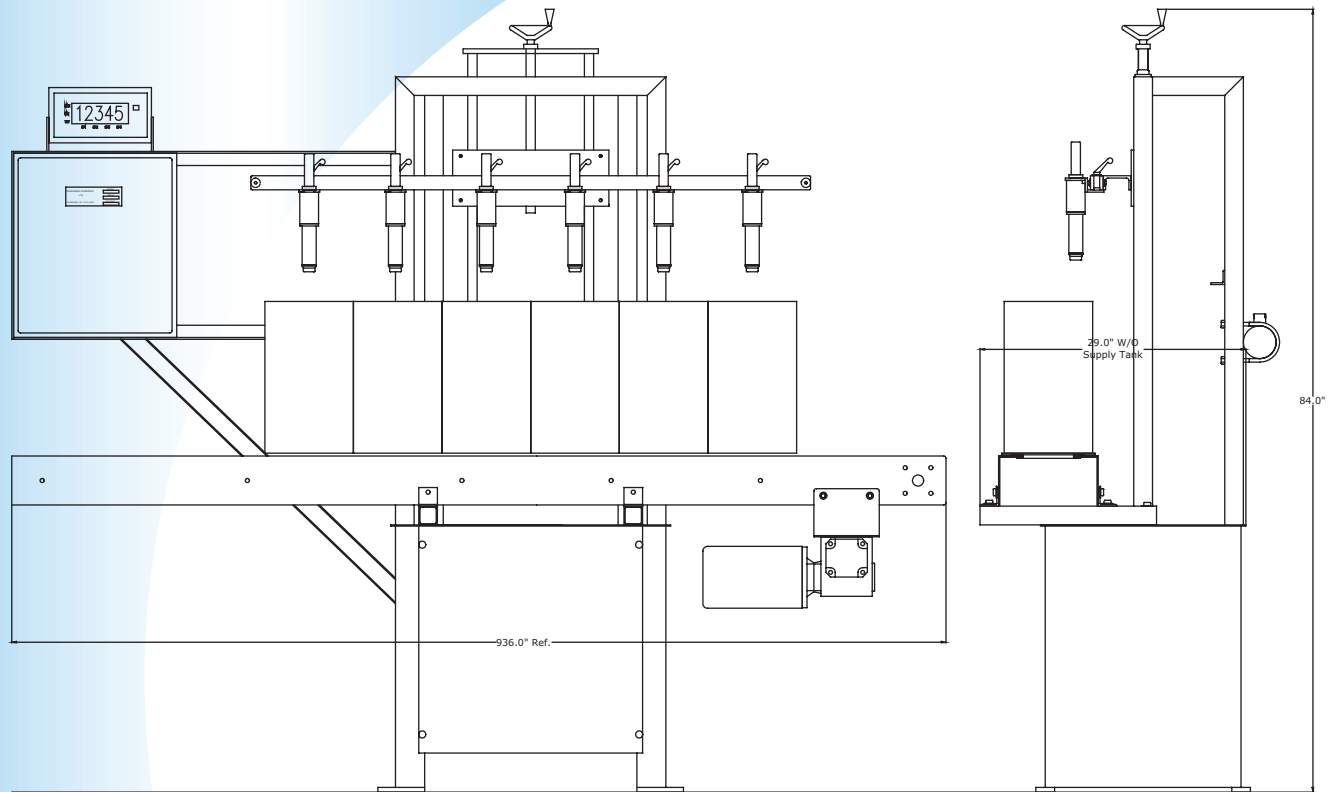

Packaging Dynamics Ltd. introduces the Mass Flow Liquid Filler which utilizes Micro Motion Coriolis flow meter mass technology. The Coriolis flow meters measure mass directly and therefore are insensitive to changes in process conditions or fluid composition. The systems meets performance requirements of manufacturers in the cosmetics, pharmaceutical, food and beverage industries. These requirements include accuracy of +/- 0.5%. Product viscosities vary from water to 40,000 cP with particulates. The Coriolis Flow meters also allow measurement of density and temperature to keep products within quality specifications. Changing over a piston filler means many hours of dismantling, cleaning and re-assembling before production can continue. The Flow Meters change over procedures are easy. The operator will simply run clean in place fluid (CIP) through the flow meters then set a new fill weight. This equipment is available from single to twelve head models and handles viscosities from water thin to gels and thick creams. Available in semi and fully-automatic variations, the Mass Flow Meters can be used to fill from fractional containers to 55 gallon drums.

Specifications

DESCRIPTION

Container size	0.5 oz to 55 gallon drums
Nozzles available	1 to 12
Construction	Stainless Steel
Overall dimensions	84" H x 29" W x 93" D (excluding supply tank)
Air Consumption	2 to 6 scfm
Weight	Approximately 700 lbs